

SMALL CANISTER INTAKE SHROUD - TOP VIEW (FULL SCALE)

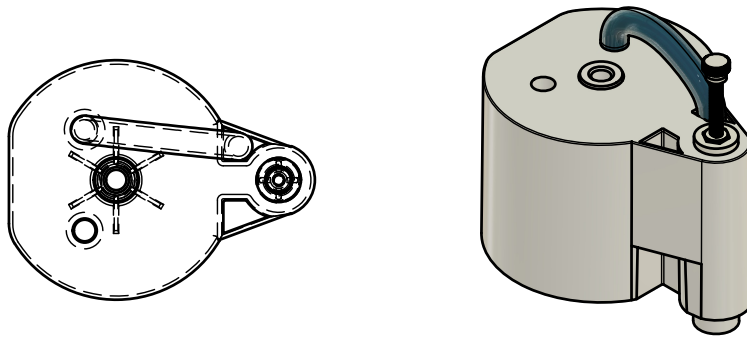

PROJECTED VIEW (1/3 SCALE)

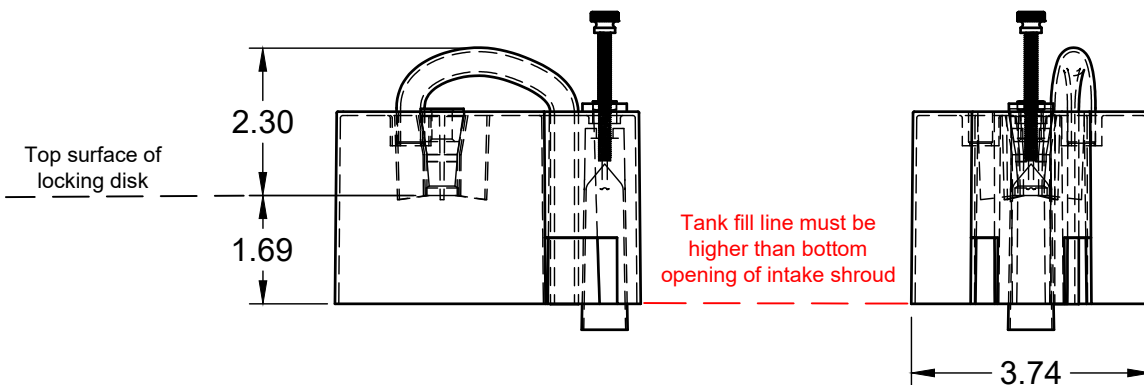

INTAKE SHROUD FITMENT TEMPLATE - TOP VIEW (FULL SCALE)

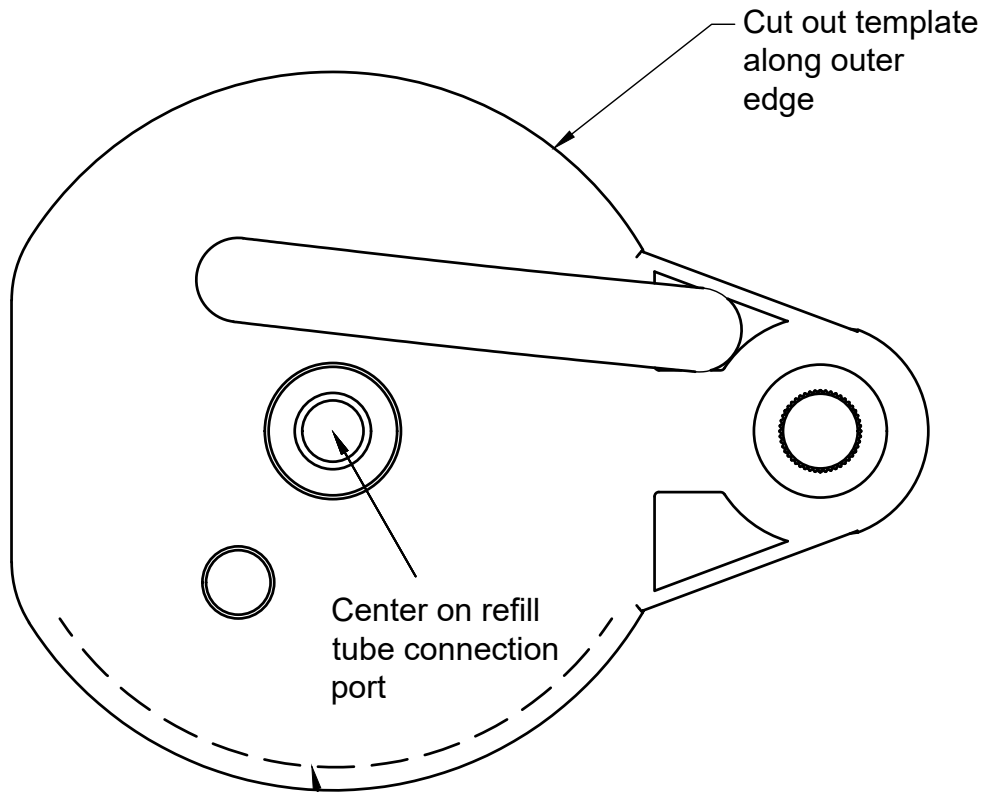

Position flusher chain tabs within curved sides of intake shroud

Clip-on flush lever chain bracket to canister center post

